

NATURA LIVING

CT0205 STAIR HANDRAIL 140 CM.
Barcode 8852410020411
Material No. Z235CT0205XXXXX18

Selling Point

1. Made from authentic pine wood, comfortable touch compare to other matel surface
2. Wood surface endure over 50 years
3. Special manufacturing process, secure from insect and bacteria
4. Weighted test up to 120 Kg.
5. wall fastening made from SUS304 stainless. Curve shape, able to support for the whole length without releasing the handle.

Product characteristics

- pices/box : 1
- Inner box weight (Kg.) : -
- Total box weight (Kg.) : -

Recommended Usage

Install on wall at stairs for support

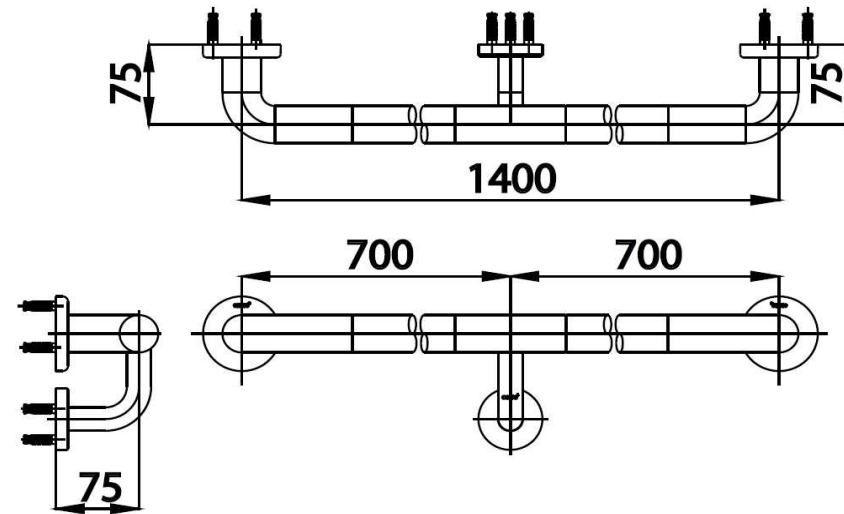

Siam Sanitary Ware Co.,Ltd. / Siam Sanitary Fittings Co.,Ltd.

36/11 Viphavadee Rangsit Rd, Sanam Bin, Donmuang, Bangkok 10210. Thailand

Tel : + 66 (0) 2973-5040-54

Fax : + 66 (0) 2973-3470

www.cotto.co.th

Export Department

Tel : + 66 (0) 2973-5040-54

Fax : + 66 (0) 2973-3472

The company reserves the right to change any of the details in the document without prior notice

COTTO
STUDIO

Center	(Donmuang ,Bangkok)	: +66 (0) 2521-7777
East	(Chonburi)	: +66 (038) 416-222
North	(Chiangmai)	: +66 (053) 211-852
North East	(Khonkean)	: +66 (043) 220-555
South	(Phuket)	: +66 (076) 261-388